

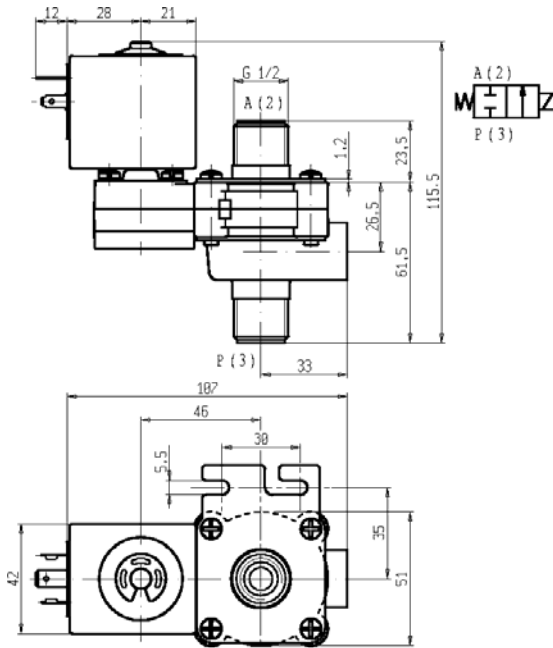

SOLENOID VALVE - DRY
2/2 - NC (Normally closed)
Direct acting - Total isolation
G 1/2

D132



► GENERAL FEATURES

Direct acting, total isolation solenoid valve: the actuator is totally isolated from the fluid so that the wetted parts are just the body and the diaphragm.
 Possibility of disassembling for inspection.
 Core duly coated by PTFE (polytetrafluoroethylene) based self lubricating material.
 Suitable to shut off liquid and gaseous fluids (verify the compatibility of fluid with materials in contact).

► TECHNICAL FEATURES

Maximum allowable pressure (PS) 2 bar
Opening time ~30ms
Closing time ~30ms
Fluid temperature -10°C +90°C
Max viscosity 5°E (~37 cStokes or mm²/s)

► MATERIALS IN CONTACT WITH FLUID

Body PPS (Polyphenylene-sulfide) reinforced
Sealing SBR or EPDM or FPM

► COIL

Continuous duty ED 100%
Encapsulation material PET (polyethylene berglass reinforced)
Coil insulation class F (140 °C)
Ambient temperature -10 C° +60 °C
Electric connenctions DIN 46340 – 3 poles connectors (DIN 43650)
Protection degree IP 65 (EN 60529) with plug connector
Voltages DC 12-24V (+10% -5%)
 AC 24V/50Hz - 110V/50Hz (120V/60Hz) - 230V/50Hz (+10% -15%)
 (Other voltages and frequencies on request).

Port size ISO 228	Orifice size (mm)	Differential pressure (bar)						Kv (m³/h)	Series and type		Power absorption			Sealings	Notes	Weight (kg)
		Δp min	Δp max				Valve		Coil	AC (VA)		DC (W)				
			Gases		Liquids					Inrush	Holding					
			AC	DC	AC	DC										
G 1/2	9	0	1,6	0,25	1,6	0,25	1,6	D132A20	Z130A	44	24	13	SBR	1	0,530	
								D132D20					EPDM	-		
								D132V20					FPM	-		

► NOTES

- Sealings : SBR = Elastomer styrol butadiene EPDM = Ethylene-propylene elastomer FPM = Fluoro-carbon elastomer
 1 - Model available on request only: ask for minimum quantity.

D132

► SPARE PARTS

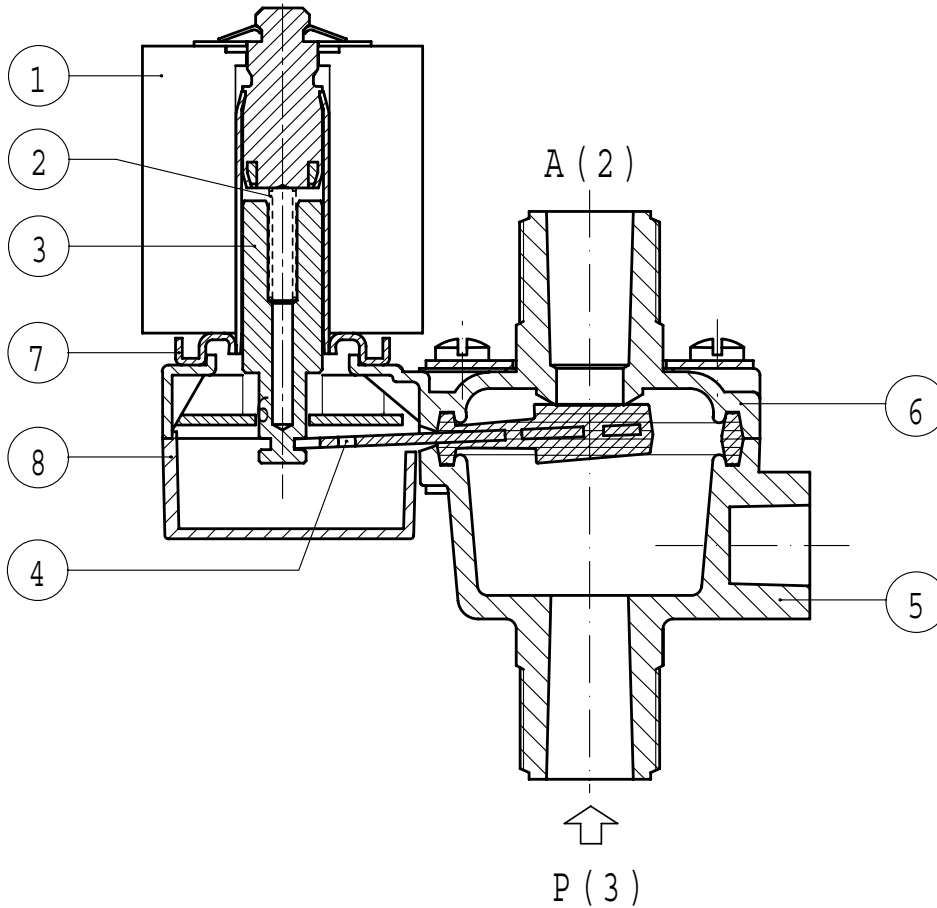

Kit description

Kit description	Kit P.N.	Consisting of:
Body kit	G2986603	Upper body pos.6 Lower body pos.5
Core kit	G2992801	Core return spring pos.2 Core pos.3
Lever seal	D132A20 3037304R D132D20 3037303R D132V20 3037301R	Lever seal pos.4
Cover	2985702R	Cover pos.8
Guide assembly	3077401R	Guide assembly pos.7
Coil	Z130A	Coil pos. 1

► INSTALLATION

- Solenoid valve can be mounted in any position.
- In case of disassembling for usual maintenance, the fixing screws have to be tightened at 1,5 Nm max torque.
- Maximum driving torque of the pipe fittings for thread connections = 15Nm.