



SOLENOID VALVE - DRY

3/2 – US (Universal service)

Direct acting - Total isolation

G 1/4 – Barbed port

D344

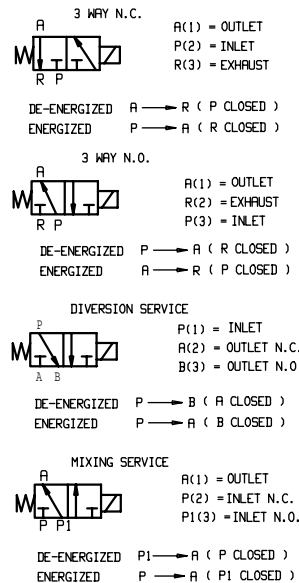
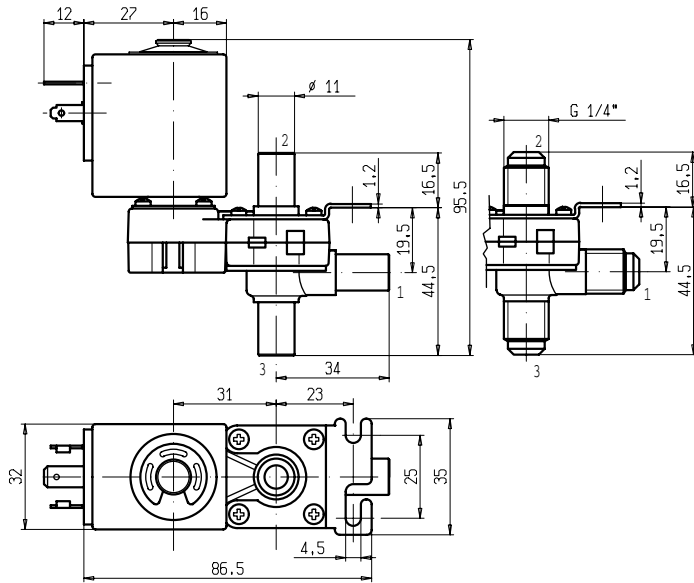

► GENERAL FEATURES

Direct acting, total isolation solenoid valve: the actuator is totally isolated from the fluid so that the wetted parts are just the body and the lever-seal.

Possibility of disassembling for inspection.

Core duly coated by PTFE (polytetrafluoroethylene) based self lubricating material.

Suitable to shut off liquid and gaseous fluids (verify the compatibility of fluid with materials in contact).

► TECHNICAL FEATURES

Maximum allowable pressure (PS) 12 bar
 Opening time ~ 25ms
 Closing time ~ 25ms
 Fluid temperature -10°C +100°C
 Max viscosity 5°E (~37 cStokes o mm²/s)

► MATERIALS IN CONTACT WITH FLUID

Body PEI (Polyetherimide)
 Sealing EPDM or VMQ or FPM

► COIL

Continuous duty ED 100%
 Encapsulation material PET (polyethylene terephthalate) fiberglass reinforced F (140°C)
 Insulation class -10 °C +60 °C
 Ambient temperature -10 °C +60 °C
 Electric connections DIN 46340 - 3 poles connector (DIN 43650)
 Protection degree IP 65 (EN 60529) with plug connector
 Voltages DC 12-24V (+10% -5%)
 AC 24V/50Hz - 110V/50Hz (120V/60Hz) – 230V/50Hz (+10% -15%)
 (Other voltages and frequencies on request)

Port size G = ISO 228	Orifice size (mm)	Differential pressure (bar)				Kv (m³/h)	Series and type		Power absorption			Sealings	Notes	Weight (kg)	
		Δp min	Δp max				Valve	Coil	AC (VA)		DC (W)				
			Gases		Liquids				Inrush	Holding					
			AC	DC	AC										DC
Barbed port G 1/4	3,2	0	1,5	1,5	1,5	1,5	0,28	D344D56	Z530A	23	14	9	EPDM	1	0,315
								D344S56					VMQ		
								D344V56					FPM		
								D344D57					EPDM		
								D344S57					VMQ		
D344V57	FPM														

► NOTES

- Sealings: EPDM = Ethylene propylene elastomer VMQ = Silicone elastomer FPM = Fluoro-carbon elastomer
- On request and depending on quantities:
 - silent execution (only for DC)
 - body in fiberglass reinforced (30%) PPOm (modified polyphenil oxide), recommended for strong basic solutions (pH≥10).
- 1 - Model available on request only: ask for minimum quantity.

D344

► SPARE PARTS

D344D-S-V56

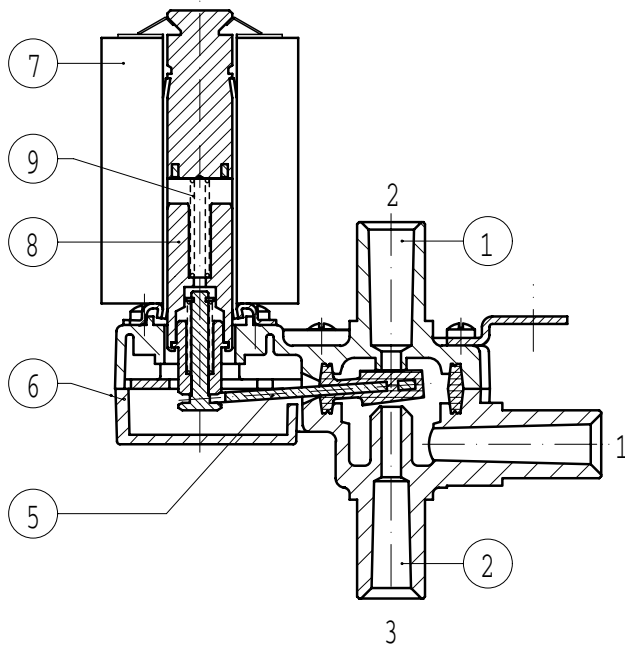

D344D-S-V57

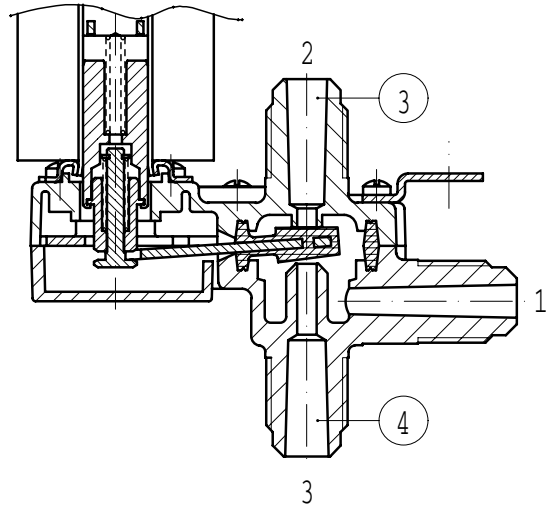

Kit description

Body kit

D344D56-S56-V56

Kit P.N.

G2846702

Consisting of:

Upper body pos.1
Lower body pos.2

D344D57-S57-V57

G2846701

Upper body pos.3
Lower body pos.4

Core kit

G2999401

Core pos.8
Core return spring pos.9

Lever seal kit

D344D56-D57
D344S56-S57
D344V56-V57

2977703R
2977704R
2977702R

Lever seal kit pos. 5

Cover

3119801R

Cover pos. 6

Coil

Z530A

Coil pos. 7

► INSTALLATION

- In case of disassembling, for usual maintenance, the fixing screws have to be tightened at 0,6 Nm max torque.
- Solenoid valve can be mounted in any position.
- Maximum driving torque of the pipe fittings for thread connections = 10Nm.