

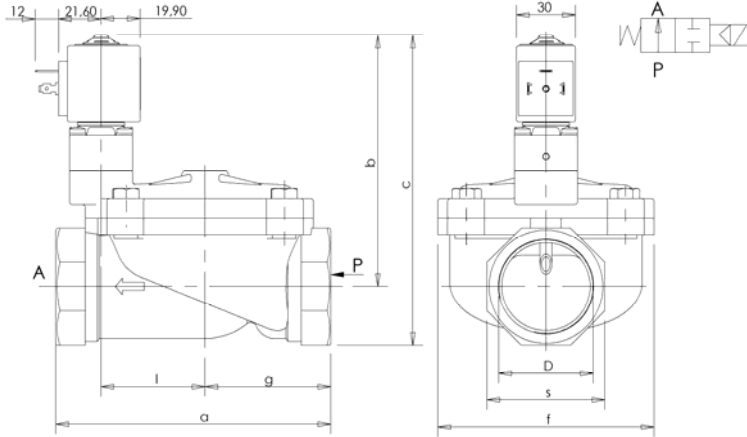

SOLENOID VALVE
2/2 - NO (Normally open)
Pilot operated
G1 ¼ ÷ 2

L280
G 1" ¼ ÷ 2"



D	a	b	c	f	g	l	s
G 1 ¼	113	125	151	81	50	40	52
G 1 ½	140	128	158	110	60	53	60
G 2	157	133	169	110	72	53	72

► GENERAL FEATURES

Diaphragm valve, pilot operated, having full orifice.
 Suitable to shut off liquid and gaseous fluids (verify the compatibility of fluid with materials in contact).
 Not suitable for use with dangerous fluids listed in Group 1, therefore they are free from CE marking in conformity with article 3 § 3 of the European Directive 97/23/EC (Pressure Equipment Directive).

► TECHNICAL FEATURES

Maximum allowable pressure (PS) 15 bar
Opening time from ~300ms to ~1500ms
Closing time from ~1000ms to ~2000ms
Fluid temperature -10°C +90°C (NBR)
 0°C +130°C (FPM)
Max viscosity 5°E (~37 cStokes o mm²/s)

► MATERIALS IN CONTACT WITH FLUID

Body Brass
Sealing NBR or FPM
Internal components Brass and stainless steel
Seat Brass
Guide assembly Stainless steel
Shading ring Copper

► COIL

Continuous duty ED 100%
Encapsulation material PET (polyethylene terephthalate) fiberglass reinforced
Coil insulation class F (155 °C) on request class H (180°C) - UL
Ambient temperature -10 C° +50 °C
Electric connection DIN 46340- 3 poles connector (DIN 43650)
Protection degree IP 65 (EN 60529) with plug connector
Voltages DC 12-24V (+10% -5%)
 AC 24V/50Hz - 110V/50Hz (120V/60Hz) - 230V/50Hz (+10% -15%)
 (Other voltages and frequencies on request).

Port size ISO 228	Orifice size (mm)	Differential pressure (bar)				Kv (m³/h)	Series and type		Power absorption			Sealings	Notes	Weight (kg)						
		Δp min	Δp max		Valve		Coil	AC (VA)		DC (W)										
			Gases	Liquids				Inrush	Holding											
G 1 ¼	30	0,50	10	10	10	10	L280B48	ZA30A	23	14	9	NBR	-	1,790						
G 1 ½	45													2,720						
G 2	45													3,130						
G 1 ¼	30													L280V48	23	14	9	FPM	-	1,790
G 1 ½	45																			2,720
G 2	45																			3,130

► NOTE

- Sealings : NBR = Nitrile-butylene elastomer FPM = Fluoro-carbon elastomer
 - Operation with gaseous fluids at high pressure without any outlet restriction, can reduce the diaphragm life.

L280 G 1" ¼ ÷ 2"

► SPARE PARTS

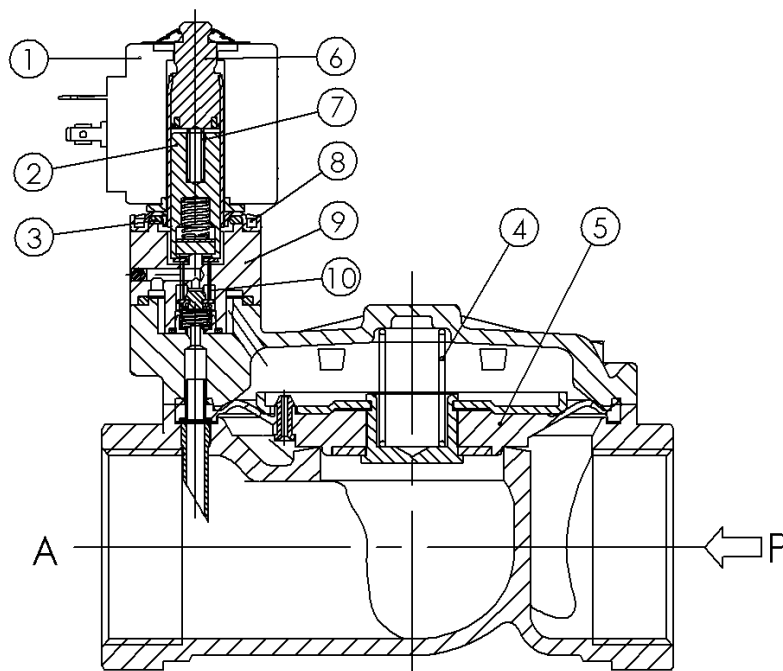

Kit description		Kit P.N.	Consisting of:
Core kit	L280B48 L280V48	G3108901 G3108902	Core pos. 2 Core OR pos. 3 Core return spring pos. 7
Reversing group kit	L280B48 L280V48	G3109101 G3109102	Reversing block pos. 9 Core return spring pos. 7 N.4 fixing screws pos. 8 Fork pos. 10
OR guide assembly	L280B48 L280V48	GU2421000053 GU2424000053	N.10 Guide group OR pos. 3
Diaphragm spring kit	G 1 ¼ G1 ½ - 2	G2401101 G2401501	N.10 diaphragm springs pos. 4
Diaphragm assembly	G 1 ¼ L280B48 G1 ½ - 2 L280B48 G 1 ¼ L280V48 G1 ½ - 2 L280V48	2400801R 2401301R 2400802R 2401302R	Diaphragm assembly pos. 5
Guide assembly		3092201R	Guide assembly pos. 6
Coil		ZA30A	Coil pos. 1

► MOUNTING

Solenoid valve can be mounted in any position; vertical with coil upwards preferred.